

Approval body for construction products
and types of construction

Bautechnisches Prüfamt

An institution established by the Federal and
Laender Governments



European Technical Assessment

ETA-11/0319
of 17 July 2014

General Part

Technical Assessment Body issuing the
European Technical Assessment:

Deutsches Institut für Bautechnik

Trade name of the construction product

Tecfi wedge Anchor AJE

Product family
to which the construction product belongs

Torque controlled expansion anchor of sizes M8, M10,
M12,
M16 and M20 for use in concrete

Manufacturer

Tecfi S.p.A
Strada Statale Appia, Km. 193
81050 PASTORANO (CE)
ITALIEN

Manufacturing plant

tecfi plant

This European Technical Assessment
contains

14 pages including 10 annexes which form an integral part
of this assessment

This European Technical Assessment is
issued in accordance with Regulation (EU)
No 305/2011, on the basis of

Guideline for European technical approval of "Metal
anchors for use in concrete", ETAG 001 Part 2: "Torque
controlled expansion anchors", April 2013,
used as European Assessment Document (EAD)
according to Article 66 Paragraph 3 of Regulation (EU)
No 305/2011.

ETA-11/0319 issued on 1 November 2012

The European Technical Assessment is issued by the Technical Assessment Body in its official language. Translations of this European Technical Assessment in other languages shall fully correspond to the original issued document and shall be identified as such.

Communication of this European Technical Assessment, including transmission by electronic means, shall be in full. However, partial reproduction may only be made with the written consent of the issuing Technical Assessment Body. Any partial reproduction has to be identified as such.

This European Technical Assessment may be withdrawn by the issuing Technical Assessment Body, in particular pursuant to information by the Commission according to Article 25 Paragraph 3 of Regulation (EU) No 305/2011.

Specific Part

1 Technical description of the product

The Tecfi Wedge anchor AJE is an anchor made of galvanised steel of sizes M8, M10, M12, M16 and M20 which is placed into a drilled hole and anchored by torque-controlled expansion.

The product description is given in Annex A.

2 Specification of the intended use in accordance with the applicable European Assessment Document

The performances given in Section 3 are only valid if the anchor is used in compliance with the specifications and conditions given in Annex B.

The verifications and assessment methods on which this European Technical Assessment is based lead to the assumption of a working life of the anchor of at least 50 years. The indications given on the working life cannot be interpreted as a guarantee given by the producer, but are to be regarded only as a means for choosing the right products in relation to the expected economically reasonable working life of the works.

3 Performance of the product and references to the methods used for its assessment

3.1 Mechanical resistance and stability (BWR 1)

Essential characteristic	Performance
Characteristic resistance for tension loads	See Annex C 1
Characteristic resistance for shear loads	See Annex C 1
Displacements under tension loads	See Annex C 3
Displacements under shear loads	See Annex C 3

3.2 Safety in case of fire (BWR 2)

Essential characteristic	Performance
Reaction to fire	Anchorage satisfy requirements for Class A1
Resistance to fire	See Annex C 2

3.3 Hygiene, health and the environment (BWR 3)

Regarding dangerous substances there may be requirements (e.g. transposed European legislation and national laws, regulations and administrative provisions) applicable to the products falling within the scope of this European Technical Assessment. In order to meet the provisions of Regulation (EU) No 305/2011, these requirements need also to be complied with, when and where they apply.

3.4 Safety in use (BWR 4)

The essential characteristics regarding Safety in use are included under the Basic Works Requirement Mechanical resistance and stability.

3.5 Protection against noise (BWR 5)

Not applicable.

3.6 Energy economy and heat retention (BWR 6)

Not applicable.

3.7 Sustainable use of natural resources (BWR 7)

The sustainable use of natural resources was not investigated.

3.8 General aspects

The verification of durability is part of testing the essential characteristics. Durability is only ensured if the specifications of intended use according to Annex B are taken into account.

4 Assessment and verification of constancy of performance (AVCP) system applied, with reference to its legal base

According to Decision of the Commission of 24 June 1996 (96/582/EC) (OJ L 254 of 08.10.96 p. 62-65), the system of assessment and verification of constancy of performance (see Annex V and Article 65 Paragraph 2 to Regulation (EU) No 305/2011) given in the following table applies.

Product	Intended use	Level or class	System
Metal anchors for use in concrete (heavy-duty type)	For fixing and/or supporting concrete structural elements or heavy units such as cladding and suspended ceilings	—	1

5 Technical details necessary for the implementation of the AVCP system, as provided for in the applicable European Assessment Document

Technical details necessary for the implementation of the AVCP system are laid down in the control plan deposited at Deutsches Institut für Bautechnik.

Issued in Berlin on 21 July 2014 by Deutsches Institut für Bautechnik

Uwe Bender
Head of Department

beglaubigt:
Lange

Installed condition

Installation for static and quasi-static loads

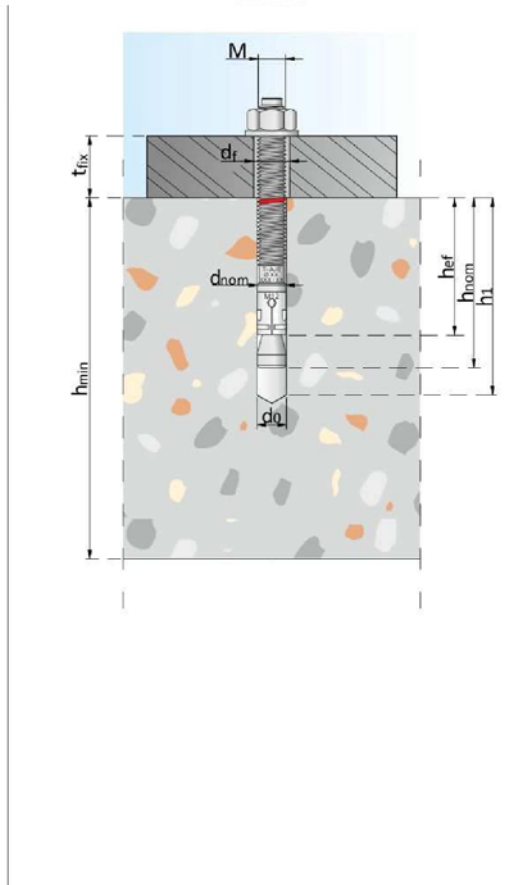

Installation for seismic performance categories C1 and C2

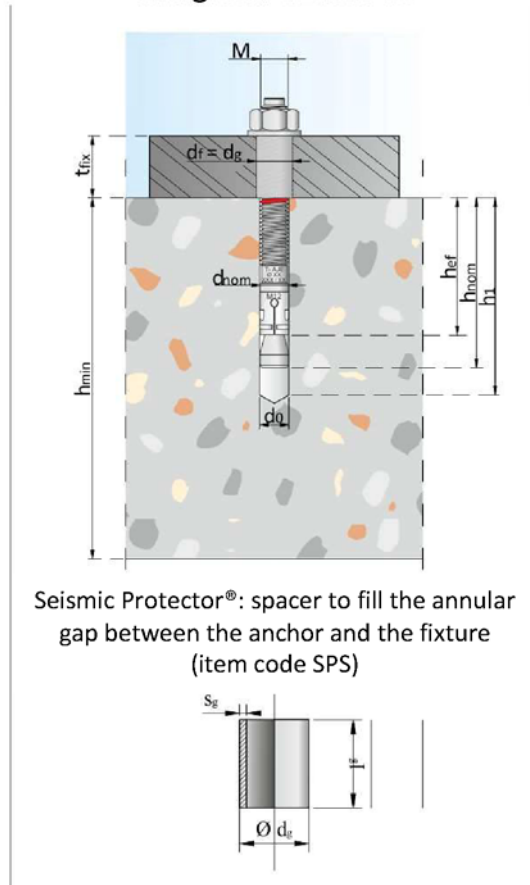

Installation details

d_{nom}	Outside diameter of the anchor
d_{cut}	Maximum cutting diameter of the drill bit
t_{fix}	Thickness of the fixtures
d_0	Diameter of the drill hole
d_f	Diameter of the clearance hole in the fixture
M	Diameter of the metric thread
h_{min}	Minimum thickness of the concrete member
h_{nom}	Overall anchor embedment depth
h_{ef}	Anchorage depth
d_g	Diameter of the spacer
l_g	Length of the spacer
s_g	Thickness of the spacer

Tecfi wedge anchor AJE

Product description
Installed condition

Annex A 1

Anchor types

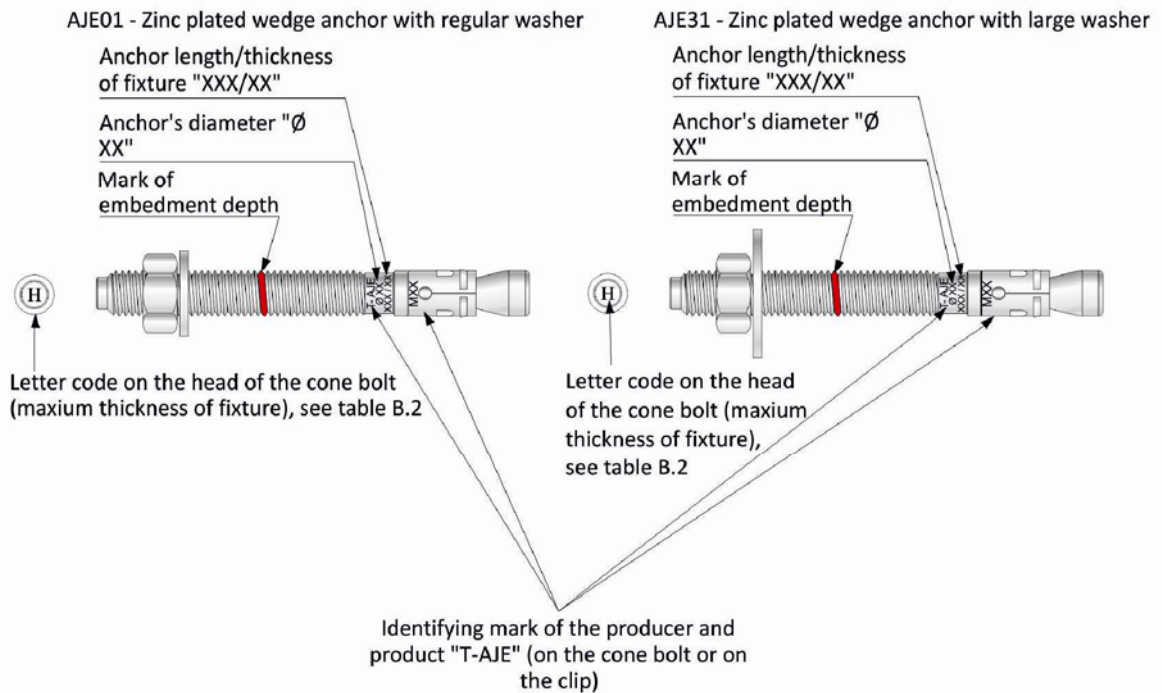

AJE 01 components:

Part	Description
1	Sleeve expansion
2	ISO 7089 regular washer
3	Hexagonal nut
4	Cone bolt

AJE 31 components:

Part	Description
1	Sleeve expansion
2	ISO 7093-1 large washer
3	Hexagonal nut
4	Cone bolt

SPS – Seismic Protector®: spacer for seismic performance categories C1 and C2



Part	Description
1	Spacer





Tecfi wedge anchor AJE

Product description
Anchor types and components

Annex A 2

Table A1: Materials and components

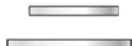
AJE 01 – AJE 31 components

Part	Component	Description
1	Cone Bolt 	Zinc plated min 5 µm (Cr VI Free) according to ISO 4042 carbon steel cone bolt, minimum tensile strength 800 N/mm ²
2	Hexagonal nut 	Zinc plated min 5 µm (Cr VI Free) according to ISO 4042 carbon steel hexagonal nut DIN 934 (or ISO 4032).
3	Washer 	Zinc plated min 5 µm (Cr VI Free) according to ISO 4042 carbon steel washer ISO 7089 (AJE01) or ISO 7093-1 (AJE31), hardness class HV 200.
4	Steel sleeve 	Zinc plated min 5 µm (Cr VI Free) according to ISO 4042 carbon steel HRB 80.

SPS components

1	Seismic Protector®, spacer for seismic performance categories C1 and C2 	Zinc plated min 5 µm (Cr VI Free) according to ISO 4042 carbon steel spacer(s).
---	--	---

Assembled anchor

For static and quasi-static loads

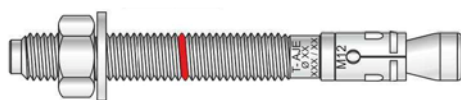

AJE 01

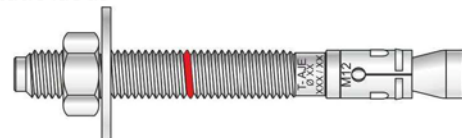

AJE 31

For seismic performance categories C1 and C2



AJE 01 + SPS

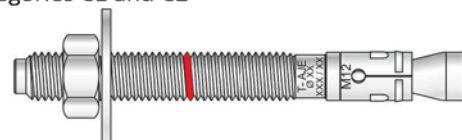

AJE 31 + SPS

Tecfi wedge anchor AJE

Product description
Materials

Annex A 3

Specifications of intended use

Anchorage subject to:

- Static and quasi-static loads: M8, M10, M12, M16, M20
- Seismic action for Performance Category C1 and C2: sizes M10, M12, M16, M20 with Seismic Protector® only
- Fire exposure: up to 120 minutes: M8, M10, M12, M16, M20

Base materials:

- Reinforced or unreinforced normal weight concrete according to EN 206-1:2000-12.
- Strength classes C20/25 to C50/60 according to EN 206-1:2000-12. (e.g.)
- Non-cracked concrete: M8, M10, M12, M16, M20
- Cracked concrete: M8, M10, M12, M16, M20.

Use conditions (Environmental conditions):

- Anchorages subject to dry internal conditions

Design:

- Anchorages are designed under the responsibility of an engineer experienced in anchorages and concrete work.
- Verifiable calculation notes and drawings are prepared taking account of the loads to be anchored. The position of the anchor is indicated on the design drawings (e.g. position of the anchor relative to reinforcement or to supports, etc.).
- Anchorages under static or quasi-static actions and under fire exposure are designed in accordance with:
 - ETAG 001, Annex C, design method A, Edition August 2010;
 - CEN TS CEN/TS 1992-4-1:2009;
- Anchorages under seismic actions are designed in accordance with:
 - EOTA Technical Report TR 045, Edition February 2013
 - Anchorages shall be positioned outside of critical regions (e.g. plastic hinges) of the concrete structure.
 - Fastenings in stand-off installation or with a grout layer are not allowed
- In case of requirements for resistance to fire exposure it must be ensured that local spalling of the concrete cover does not occur.

Installation:

- Hole drilling by rotary plus hammer mode: M8, M10, M12, M16, M20
- Anchor installation carried out by appropriately qualified personnel and under the supervision of the person responsible for technical matters of the site.
- In case of aborted hole: new drilling at a minimum distance away of twice the depth of the aborted hole or smaller distance if the aborted hole is filled with high strength mortar and if under shear or oblique tension load it is not the direction of the load application.

Tecfi wedge anchor AJE

Intended Use
Specifications

Annex B 1

Table B1: Installation details

Anchor size			M 8	M 10	M 12	M 16	M 20
Nominal drill hole diameter	d_0	[mm]	8	10	12	16	20
Maximum cutting diameter of drill bit	d_{cut}	[mm]	8,45	10,45	12,5	16,5	20,55
Maximum torque moment	T_{inst}	[Nm]	20	45	60	110	200
Minimum allowable spacing (even in case of fire exposure)	s_{min}	[mm]	80	65	75	130	170
Minimum allowable edge distance	c_{min}	[mm]	80	80	90	130	200
Wrench size	SW	[mm]	13	17	19	24	30
Overall anchor embedment depth	h_{nom}	[mm]	55	70	85	100	115
Minimum thickness of concrete member	h_{min}	[mm]	100	110	140	170	200
Depth of the drilled hole to deepest point	h_1	[mm]	65	85	105	120	135
Diameter of clearance hole in the fixture	d_f	[mm]	9	12	14	18	22
Thickness of fixture	t_{fix}	[mm]	≤ 160	≤ 160	≤ 270	≤ 320	≤ 320
Nominal outside diameter of the spacer for seismic performance categories C1 and C2	d_g	[mm]	NPD	12	14	18	22
Nominal length of the spacer for seismic performance categories C1 and C2	l_g	[mm]	NPD	The total length of the spacer must be equal to the thickness of the fixture, with a tolerance of: - for $t_{fix} \leq 120$ [mm]: + 0 - 3 [mm]; - for $t_{fix} > 120$ [mm]: + 0 - 5 [mm]. More spacers can be used to reach the total length			
Minimum edge distance (fire exposure on one side)	c_{min}	[mm]	$2 h_{ef}$				
Minimum edge distance (fire exposure if fire attacks from more than one side)	c_{min}	[mm]	If fire attacks from more than one side, the minimum edge distance shall be ≥ 300 mm or $\geq 2 h_{ef}$				

Table B2: Details of letter code on the head

Letter code on the head of cone bolt *	A	B	C	D	E	F	G	H	I	K	L	M	N	O	P	R	S
Maximum thickness of fixture	5	10	15	20	25	30	35	40	45	50	55	60	65	70	80	90	100

*For $100 < t_{fix} \leq 200$ there is the number 1 before the letter code;

$200 < t_{fix} \leq 300$ there is the number 2 before the letter code;

$300 < t_{fix} \leq 400$ there is the number 3 before the letter code;

Tecfi wedge anchor AJE

Intended use
Installation parameters

Annex B 2

Drill bit

	AJE anchor size	Drill bit item code
	Ø 8 (M 8)	EO 01 08 210
	Ø 10 (M 10)	EO 01 10 210
	Ø 12 (M 12)	EO 01 12 210
	Ø 16 (M 16)	EO 01 16 210
Ø 20 (M 20)	EO 01 20 210	

Blowing pump



Seismic Protector®

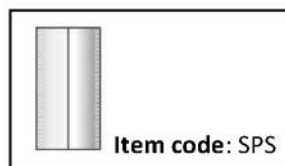

Tecti wedge anchor AJE

Intended Use
Cleaning and setting tools

Annex B 3

Installation instructions for static and quasi-static loads

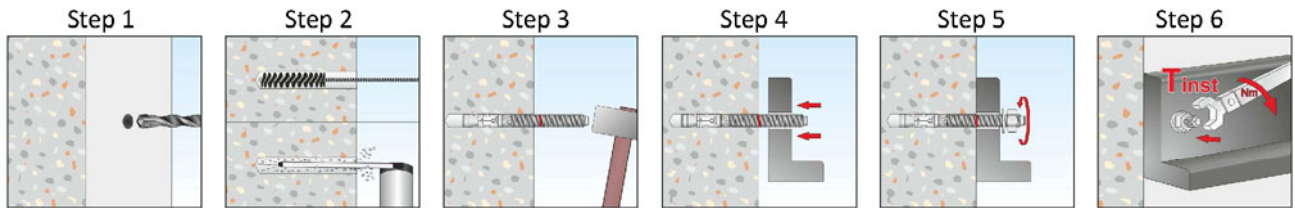

Step 1	Drill a hole into the concrete in rotary plus hammer mode
Step 2	Remove the dust into the hole using a brush and a blowing pump
Step 3 ¹⁾	Hammer the anchor into the hole
Step 4 ¹⁾	Place the fixture
Step 5 & 6	Apply the required torque moment T_{inst}

¹⁾ Through fixing is allowed (place the fixture before placing the anchor)

Installation instructions for seismic performance categories C1 and C2

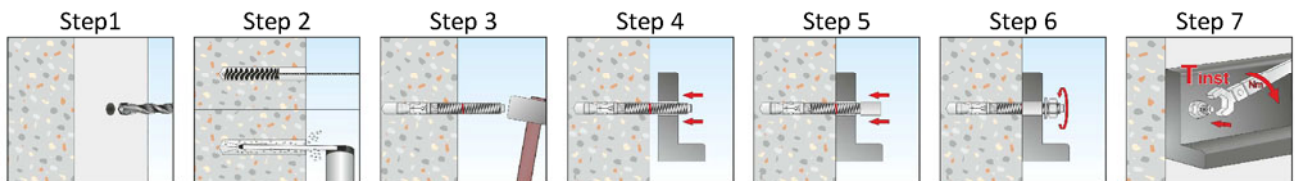

Step 1	Drill a hole into the concrete in rotary plus hammer mode
Step 2	Remove the dust into the hole using a brush and a blowing pump
Step 3 ²⁾	Hammer the anchor in the hole
Step 4 ²⁾	Place the fixture
Step 5 ³⁾	Insert the spacer to fill the annular gap between the anchor and the fixture
Step 6 & 7	Apply the required torque moment T_{inst}

²⁾ Through fixing is allowed (place the fixture before placing the anchor)

³⁾ Size and number of the spacers depends on the anchor size and the thickness of fixture

Tecfi wedge anchor AJE

Intended use
Installation instruction

Annex B 4

Table C1: Performances for design method A

Anchor size			M 8	M 10	M 12	M 16	M 20
Steel failure							
Characteristic resistance	$N_{Rk,s}$	[kN]	16	25	40	70	115
	$N_{Rk,s,seisC1}$	[kN]					
	$N_{Rk,s,seisC2}$	[kN]					
	$V_{Rk,s}$	[kN]	12	20	35	60	95
	$V_{Rk,s,seis,C1}$	[kN]	NPD	10	17	24	45
	$V_{Rk,s,seis,C2}$	[kN]	NPD	10	17	24	45
	$M_{Rk,s}^0$	[Nm]	30	60	105	266	519
Partial safety factor	$\gamma_{Ms,N}$	[-]	1,5				
Pull-out failure							
Characteristic resistance in uncracked concrete C20/25	$N_{Rk,p,ucr}$	[kN]	7,5	16	20	Not relevant	
Characteristic resistance in cracked concrete C20/25	$N_{Rk,p,cr}$	[kN]	6	9	16	25	30
Characteristic resistance under seismic performance category C1	$N_{Rk,p,seis,C1}$	[kN]	NPD	3,2	12,8	25	30
Characteristic resistance under seismic performance category C2	$N_{Rk,p,seis,C2}$	[kN]	NPD	2,1	3,2	15,1	16,1
Increasing factor for concrete	C30/37	ψ_c	[-]	1,22			
	C40/50			1,41			
	C50/60			1,55			
Installation safety factor	γ_2	[-]	1,20			1,00	
Concrete cone failure							
Effective anchorage depth	h_{ef}	[mm]	45	55	70	75	90
Factor ²⁾	k_{cr}		7,2				
	k_{ucr}		10,1				
Spacing	$s_{cr,N}$	[mm]	3 h_{ef}				
Edge distance	$c_{cr,N}$	[mm]	1,5 h_{ef}				
Splitting failure							
Spacing	$s_{cr,sp}$	[mm]	200	280	300	430	400
Edge distance	$c_{cr,sp}$	[mm]	100	140	150	215	200
Concrete pry-out failure							
k factor	$k^{1) = k_3^{2)}$	[-]	1,0			2,0	
Concrete edge failure							
Effective length of anchor	$l_f = h_{ef}$	[mm]	45	55	70	75	90
Outside diameter of anchor	d_{nom}	[mm]	8	10	12	16	20

¹⁾ for design according to ETAG 001 Annex C

²⁾ for design according to CEN/TS 1992-4:2009

Tecfi wedge anchor AJE

Performances

for static and quasi-static action and for seismic performance categories C1 and C2

Annex C 1

Table C3: Performances under fire exposure in concrete C20/25 to C50/60

Anchor size				M 8	M 10	M 12	M 16	M 20
Steel Failure								
Characteristic resistance to tension and shear loads	R30	$F_{Rk,s,fi,30}$	[kN]	0,37	0,87	1,69	3,14	4,90
	R60	$F_{Rk,s,fi,60}$	[kN]	0,33	0,75	1,26	2,36	3,68
	R90	$F_{Rk,s,fi,90}$	[kN]	0,26	0,58	1,10	2,04	3,19
	R120	$F_{Rk,s,fi,120}$	[kN]	0,18	0,46	0,84	1,57	2,45
Characteristic bending moments	R30	$M_{Rk,s,fi,30}^0$	[Nm]	0,4	1,1	2,6	6,7	13,0
	R60	$M_{Rk,s,fi,60}^0$	[Nm]	0,3	1,0	2,0	5,0	9,7
	R90	$M_{Rk,s,fi,90}^0$	[Nm]	0,3	0,7	1,7	4,3	8,4
	R120	$M_{Rk,s,fi,120}^0$	[Nm]	0,2	0,6	1,3	3,3	6,5
Pull-out failure								
Characteristic Resistance	R 30 to R 90	$N_{Rk,p,fi}$	[kN]	1,5	2,25	4,00	6,25	7,5
	R 120	$N_{Rk,p,fi,120}$	[kN]	1,2	1,8	3,2	5,0	6,0
Concrete cone failure								
Characteristic Resistance	R 30 to R 90	$N_{Rk,c,fi}$	[kN]	1,4	2,5	5,6	9,4	13,5
	R 120	$N_{Rk,c,fi,120}$	[kN]	1,1	2,0	4,5	7,5	10,8
Concrete pry-out failure								
The characteristic resistance $V_{rk,cp,fi,Ri}$ in concrete C20/25 to C50/60 is determined by: $V_{Rk,c,fi(90)} = k \times N_{Rk,c,fi(90)} (\leq R90)$ and $V_{Rk,c,fi(120)} = k \times N_{Rk,c,fi(120)}$ (up to R120)								
Concrete edge failure								
The characteristic resistance $V_{rk,cp,fi,Ri}$ in concrete C20/25 to C50/60 is determined by: $V_{Rk,c,fi(90)}^0 = 0,25 \times V_{Rk,c}^0$ (R30, R60, R90) and $V_{Rk,c,fi(120)}^0 = 0,20 \times V_{Rk,c}^0$ (R120) with $V_{Rk,c}^0$ as an initial value of the characteristic resistance of a single anchor in cracked concrete C20/25								
Edge distance								
R30 to R120		$C_{cr,N}$	[mm]	2 h_{ef}				
If fire attack comes from more than one side, the edge distance of the anchor has to be ≥ 300 mm or $\geq 2 h_{ef}$								
Anchor spacing								
R30 to R120		$S_{cr,N}$	[mm]	4 h_{ef}				

Tecfi wedge anchor AJE

Performances
For fire exposure

Annex C 2

Table C2: Displacements

Anchor size			M 8	M 10	M 12	M 16	M 20
Displacements under static and quasi-static <u>tension</u> loads							
Service tension load in uncracked concrete C20/25 to C50/60	N_{ucr}	[kN]	3,30	6,40	7,90	16,70	23,30
Short term displacement	$\delta_{N0,cr}$	[mm]	0,02	0,01	0,03	0,08	0,05
Long term displacement	$\delta_{N\infty,cr}$	[mm]	-	-	0,03	-	-
Service tension load in cracked concrete C20/25 to C50/60	N_{cr}	[kN]	2,40	3,60	6,40	11,90	16,70
Short term displacement	$\delta_{N0,cr}$	[mm]	0,10	0,06	0,20	0,21	0,31
Long term displacement	$\delta_{N\infty,cr}$	[mm]	1,02	0,60	0,84	1,40	0,55
Displacements under static and quasi-static <u>shear</u> loads							
Service shear load in cracked and uncracked concrete C20/25 to C50/60	V_{cr}	[kN]	5,7	9,5	16,7	28,6	45,2
Short term displacement	δ_{V0}	[mm]	2,0	2,0	3,0	4,0	6,0
Long term displacement	$\delta_{V\infty}$	[mm]	3,0	4,0	6,0	8,0	10,0
Displacements for <u>Seismic performance category C2</u>							
Damage Limit State - Tension load	$\delta_{N,seis(DLS)}$	[mm]	NPD	2,39	1,74	3,34	2,48
Ultimate Limit State - Tension load	$\delta_{N,seis(ULS)}$	[mm]		10,54	15,07	14,26	10,80
Damage Limit State - Shear load	$\delta_{V,seis(DLS)}$	[mm]		3,45	3,24	4,98	4,56
Ultimate Limit State - Shear load	$\delta_{V,seis(ULS)}$	[mm]		6,21	8,37	9,00	9,64

Tecfi wedge anchor AJE

Performances
Displacements

Annex C 3